

**USA** office: Fontana   **AUS** office: Truganina   **FRA** office: Saint Vigor d'Ymonville  
**GBR** office: FDS Corporation Limited, Unit 4, Blackacre Road, Great Blakenham,  
Ipswich, Ip6 0FL, United Kingdom

If you're having difficulty, our friendly  
customer team is always here to help.



USA:cs.us@costway.com  
AUS:cs.au@costway.com  
GBR:cs.uk@costway.com  
FRA:cs.fr@costway.com

Folding Bed with Storage Cabinet  
Lit Pliant avec Armoire de Rangement

**HU11021CF**

THIS INSTRUCTION BOOKLET CONTAINS **IMPORTANT** SAFETY INFORMATION.  
PLEASE READ AND KEEP FOR FUTURE REFERENCE.

EN



### Before You Start

- ⚠ Please read all instructions carefully.
- ⚠ Retain instructions for future reference.
- ⚠ Separate and count all parts and hardware.
- ⚠ Read through each step carefully and follow the proper order.
- ⚠ We recommend that, where possible, all items are assembled near to the area in which they will be placed in use, to avoid moving the product unnecessarily once assembled.
- ⚠ Always place the product on a flat, steady and stable surface.
- ⚠ Keep all small parts and packaging materials for this product away from babies and children as they potentially pose a serious choking hazard.

FR



### Avant de Commencer

- ⚠ Veuillez lire attentivement toutes les instructions.
- ⚠ Conservez les instructions pour vous y référer ultérieurement.
- ⚠ Vérifiez toutes les pièces et les accessoires.
- ⚠ Lisez attentivement chaque étape et suivez l'ordre correct.
- ⚠ Nous recommandons que, dans la mesure du possible, tous les produits soient assemblés à proximité de la zone où ils seront utilisés, afin d'éviter tout déplacement inutile du produit une fois assemblé.
- ⚠ Placez toujours le produit sur une surface plane et stable.
- ⚠ Conservez toutes les petites pièces de ce produit et les matériaux d'emballage hors de portée des bébés et des enfants, car ils pourraient présenter un risque d'étouffement.

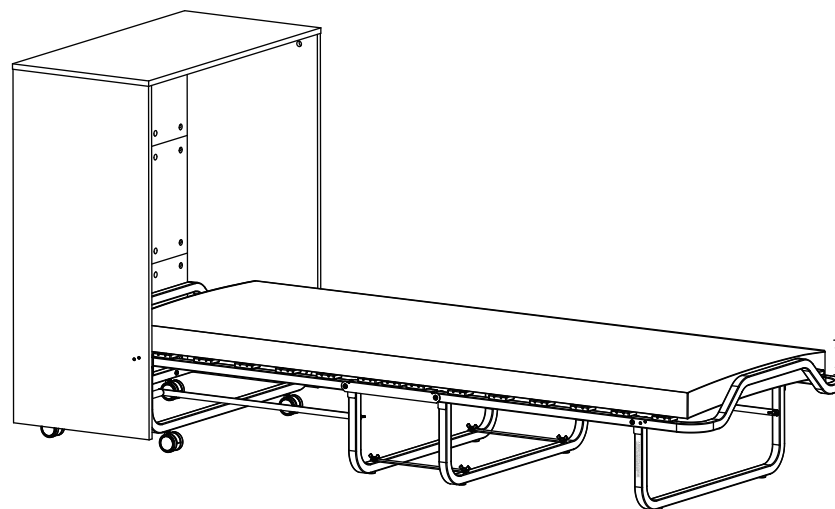



**EN: Wear gloves before installation!**  
**FR: Portez des gants avant l'installation !**

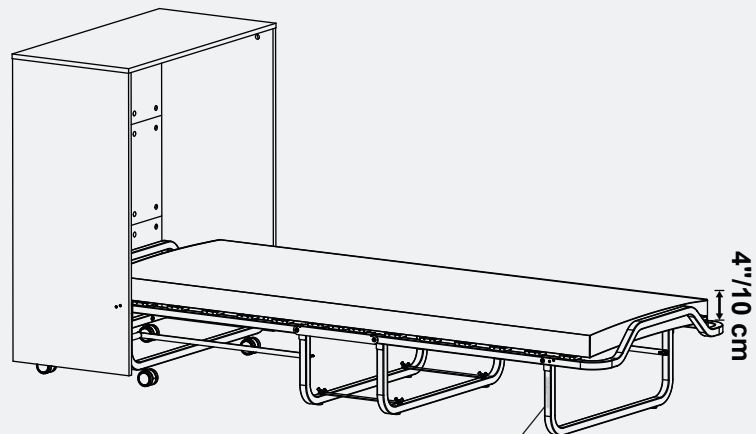

**EN: Please open the product completely and lock the latch before use!**  
**FR: Veuillez ouvrir complètement le produit et verrouiller le loquet avant de l'utiliser !**

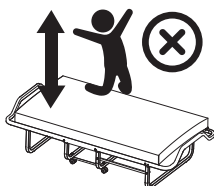

**EN: Do not jump on the folding bed**  
**FR: Ne sautez pas sur le lit pliant**



**EN: Do not sit on the edges**  
**FR: Ne vous asseyez pas sur les bords**

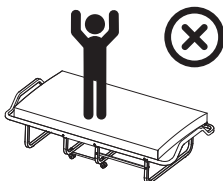

**EN: Do not stand up on the folding bed**  
**FR: Ne vous tenez pas debout sur le lit pliant**

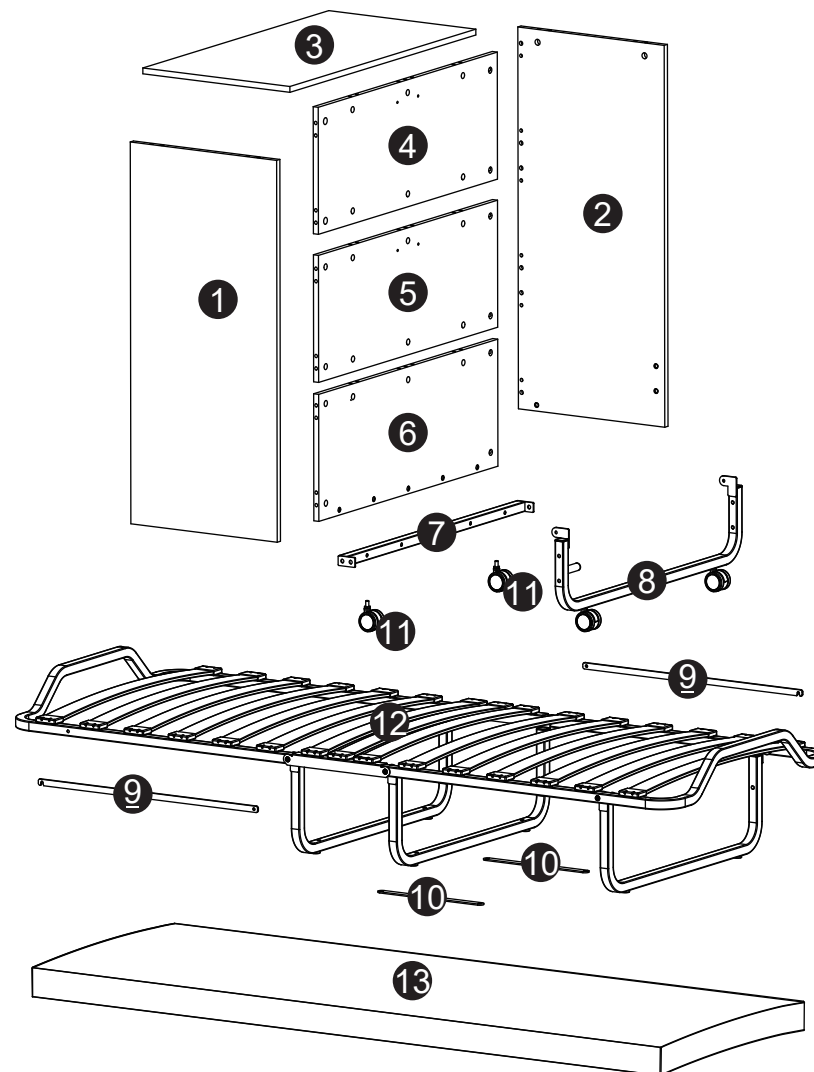
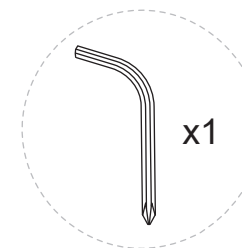
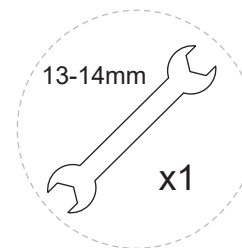
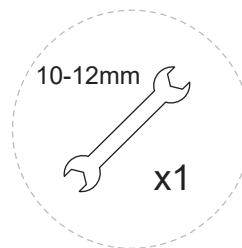

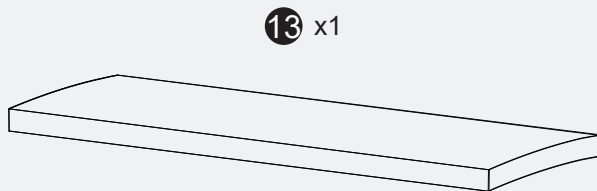
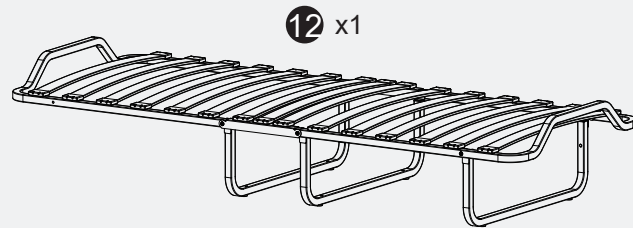
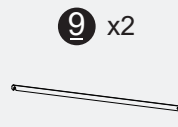
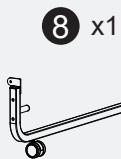
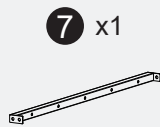
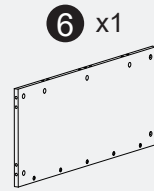
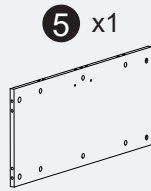
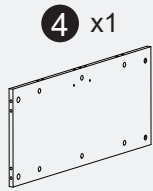
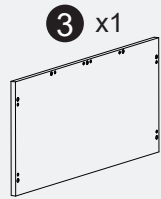
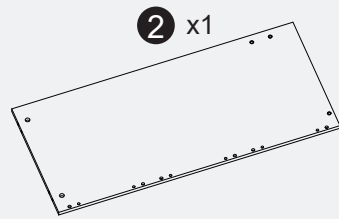
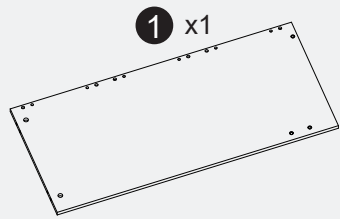

**A** x4

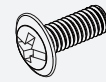

M4\*18

**B** x2

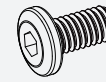

M6\*10

**C** x11

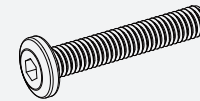

M6\*35

**D** x8

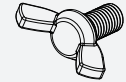

M6\*15

**E** x2



M6

**F** x20

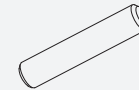

Φ8\*40MM

**G** x8



Φ8\*60MM

**H** x6

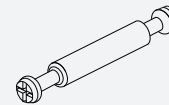

**I** x19

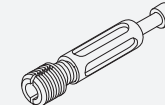

**J** x31







**K** x31

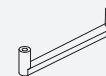

**L** x2

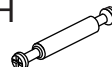

1

F  Φ8*40MM x20	G  Φ8*60MM x8	H  x6
I  x19	J  x6	

3 x1

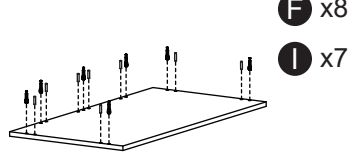

5 x1

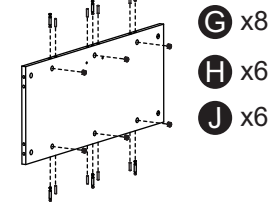



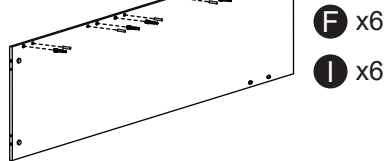

1 x1

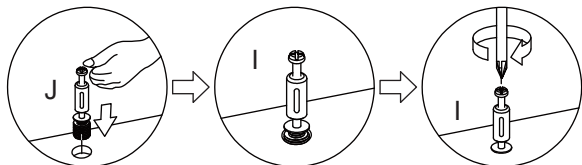
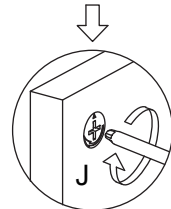
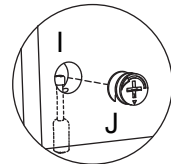
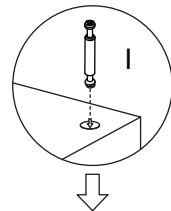
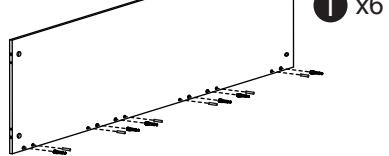

2 x1



2

A  x4	C  x5	J  x6
K  x12	L  x2	

L x2

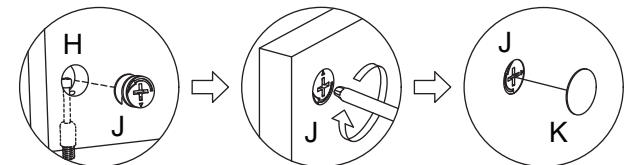
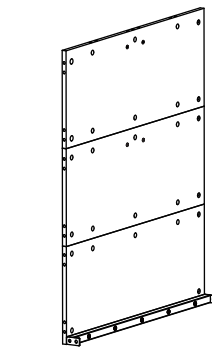
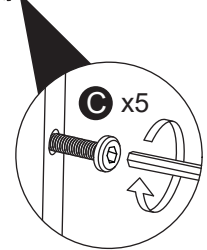
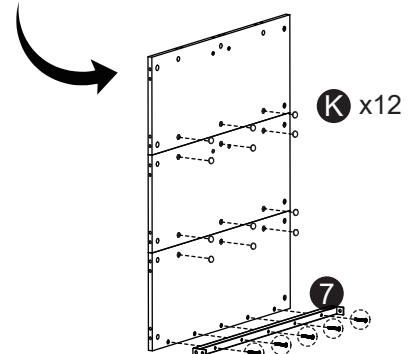
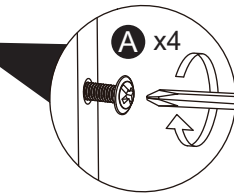
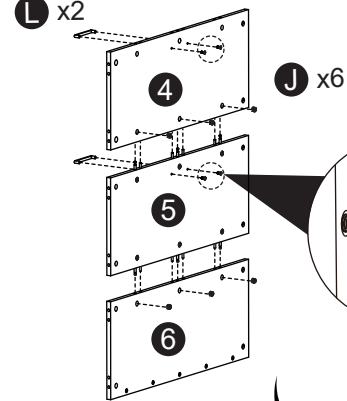

**3**

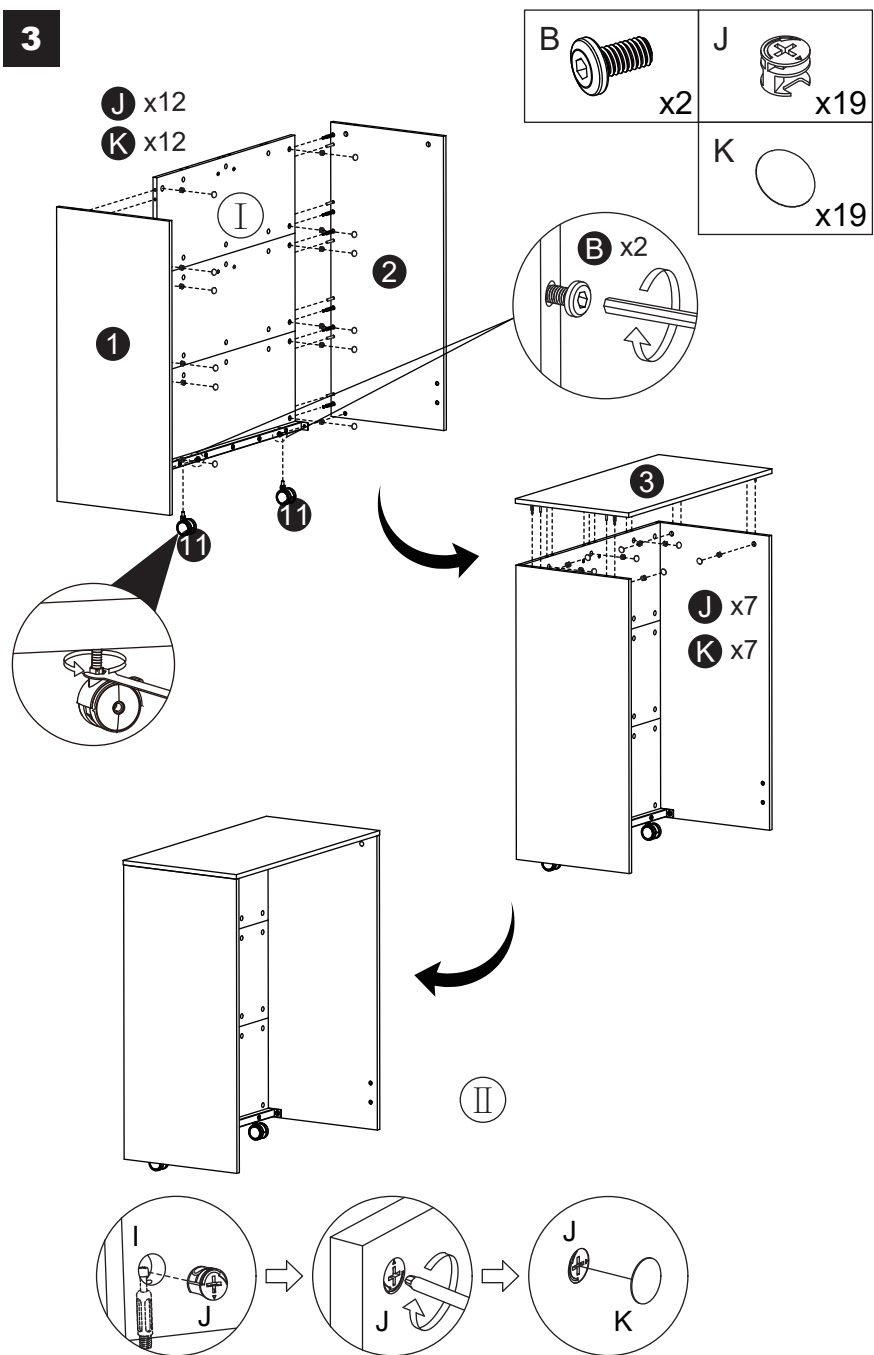

**4**

Hook and loop fasteners  
/ Fermetures auto-agrippantes

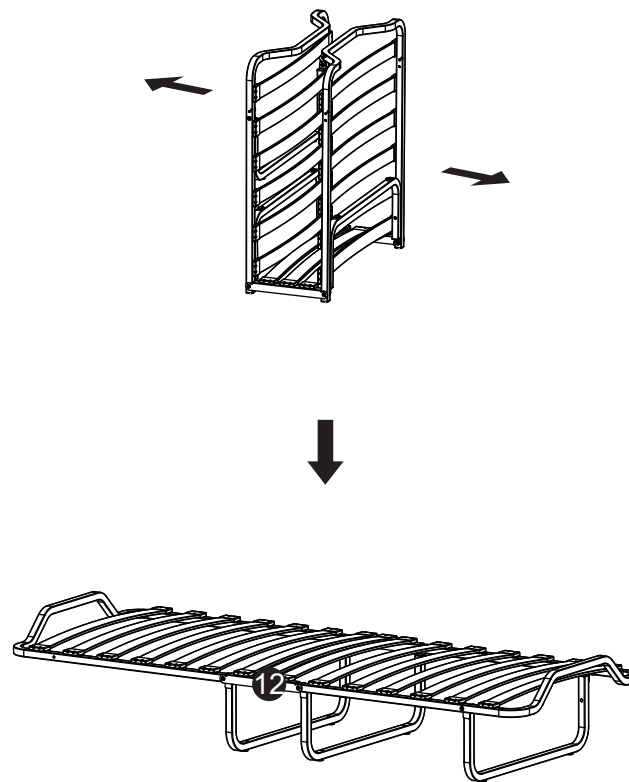

5

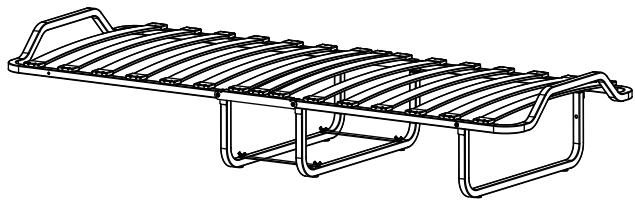
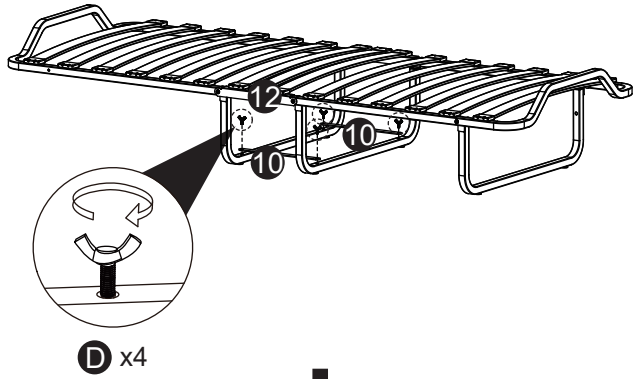
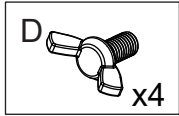

III

6

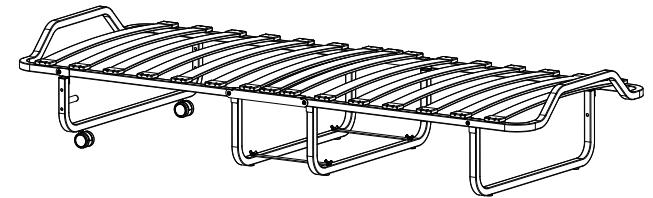
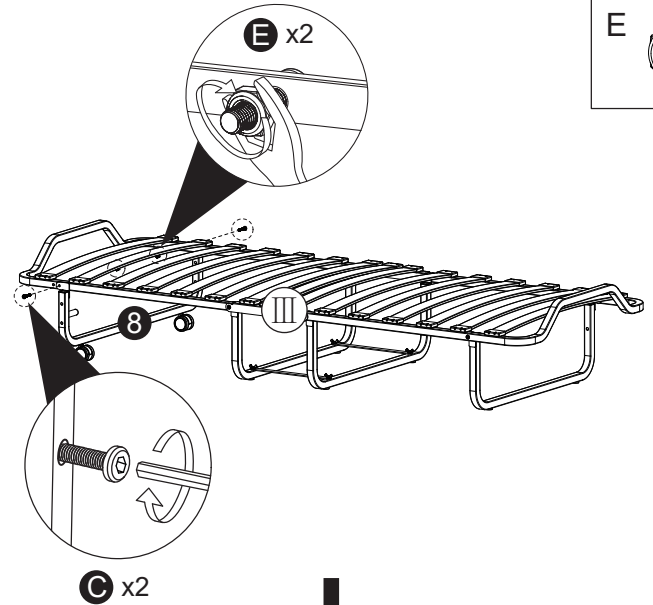
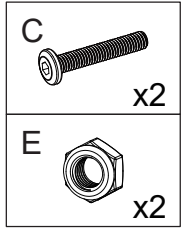

IV

7

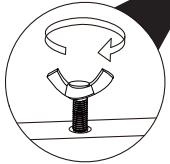
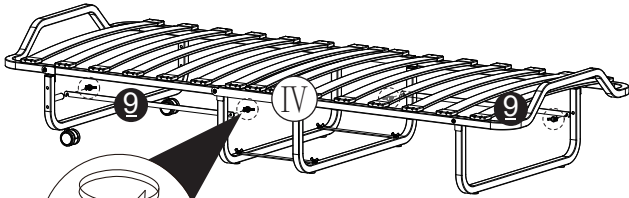
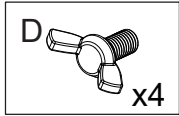

D x4

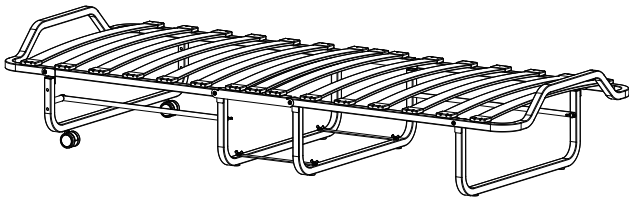

V

8

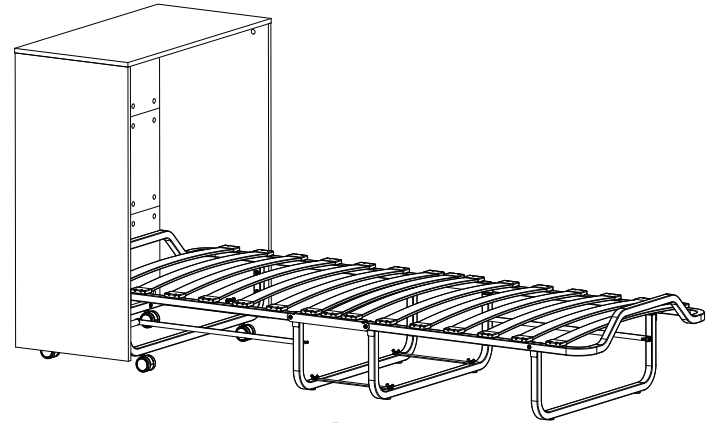
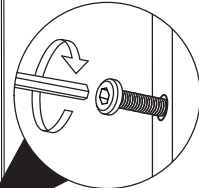
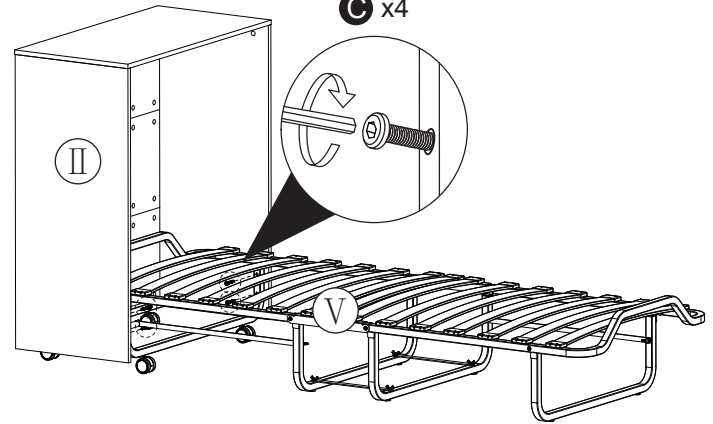
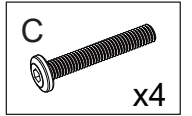

VI

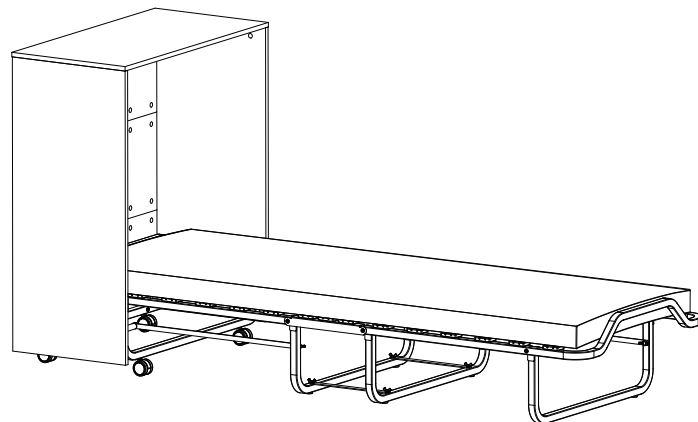
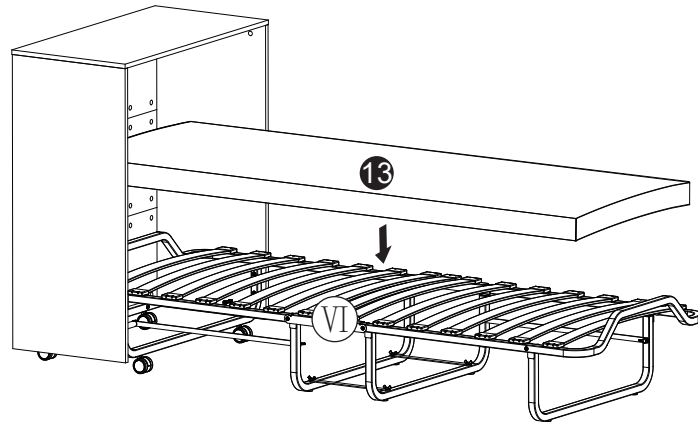

EN



### Return / Damage Claim Instructions

- ⚠ **DO NOT discard the box / original packaging.**  
In case a return is required, the item must be returned in original box. Without this your return will not be accepted.
- ⚠ **Take a photo of the box markings.**  
A photo of the markings (text) on the side of the box is required in case a part is needed for replacement. This helps our staff identify your product number to ensure you receive the correct parts.
- ⚠ **Take a photo of the damaged part (if applicable).**  
A photo of the damage is always required to file a claim and get your replacement or refund processed quickly. Please make sure you have the box even if it is damaged.
- ⚠ **Send us an email with the images requested.**  
Email us directly from marketplace where your item was purchased with the attached images and a description of your claim.

FR



### Instructions De Retour / Réclamation De Dommages

- ⚠ **NE PAS jeter la boîte/l'emballage d'origine.**  
Dans le cas où un retour est requis, l'article doit être retourné dans sa boîte d'origine. Sans cela, votre retour ne sera pas accepté.
- ⚠ **Prenez une photo des marquages de la boîte.**  
Une photo des marquages (texte) sur le côté de la boîte est requise au cas où une pièce serait nécessaire pour le remplacement. Cela aide notre personnel à identifier votre numéro de produit pour s'assurer que vous recevez les bonnes pièces.
- ⚠ **Prenez une photo des dommages (le cas échéant).**  
Une photo des dommages est toujours requise pour déposer une réclamation et obtenir rapidement votre remplacement ou votre remboursement. Assurez-vous d'avoir la boîte même si elle est endommagée.
- ⚠ **Envoyez-nous un e-mail avec les images demandées.**  
Envoyez-nous un e-mail directement depuis le marché où votre article a été acheté avec les images ci-jointes et une description de votre réclamation.